



Lecture 20:

Regulation of gene expression
II. Lambda (λ) phage repressor

Course 281

Lessons for life



An arrow can only be shot by pulling it backward. When life is dragging you back with difficulties, it means it's going to launch you into something great. So just focus, and keep aiming.

AIMS

- Understand the life cycle of lambda phage.
- Understand the general features of phage genome.
- Understand the lambda repressor molecular switch for choosing a life cycle pathway.
- Understand when a lytic pathway is chosen.
- Understand when a lysogenic pathway is chosen.

Lambda phage λ

What is a phage?

How it reproduces?

- Bacteriophages exist by invading and manipulating bacterial host cells.
- Many elements involved in the reproduction of a phage are provided by the host cell machinery.

Lambda phage λ

What is the characteristic of phage genome in phage particle?

What is the characteristic of phage genome in host cell?

Lambda Phage λ

- **Bacteriophage (lambda λ):** has a linear genome (ds DNA) enclosed a protein body.
- The linear genome contains sticky ends/overhang (**single strand DNA on each end**).

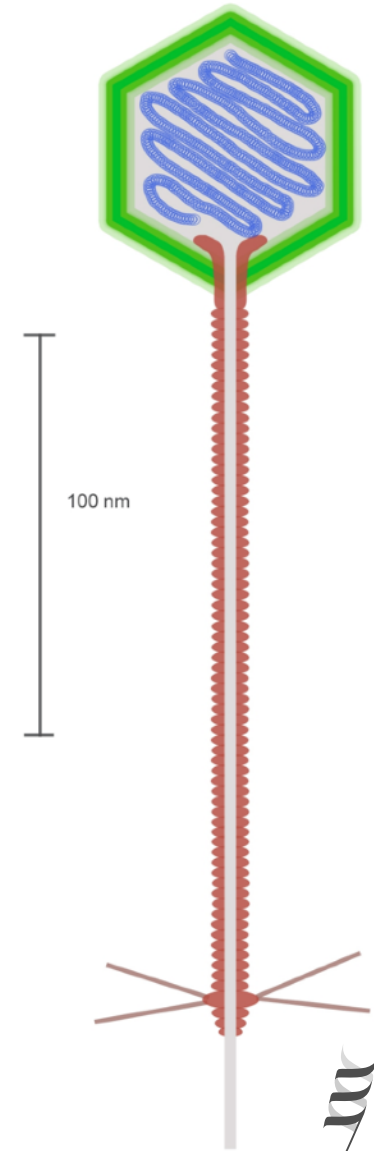
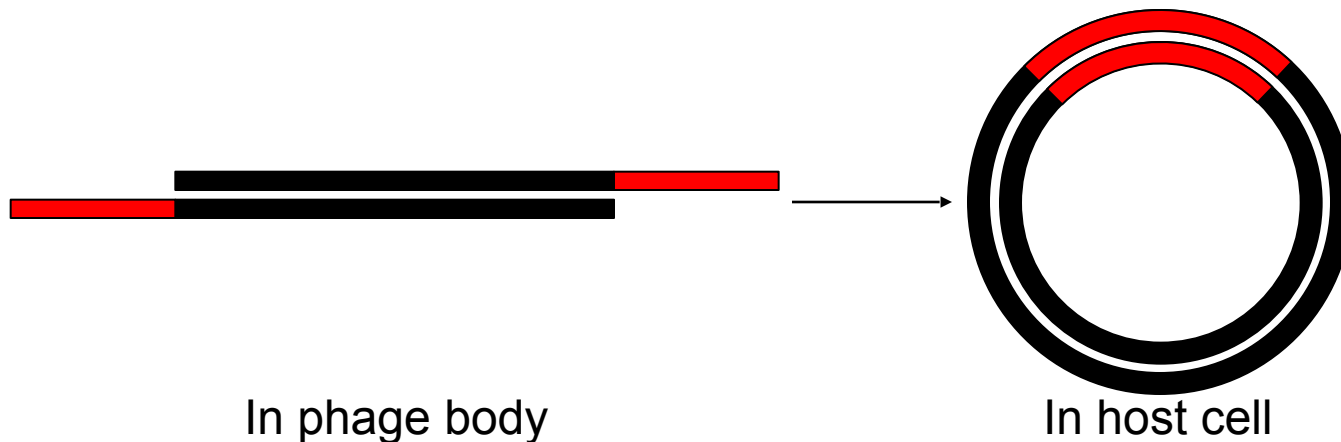

Lambda Phage λ

- The sticky ends are complementary to each other.
- When the linear DNA of a phage is injected into a host cell, the sticky ends complement each other to make a circular DNA.

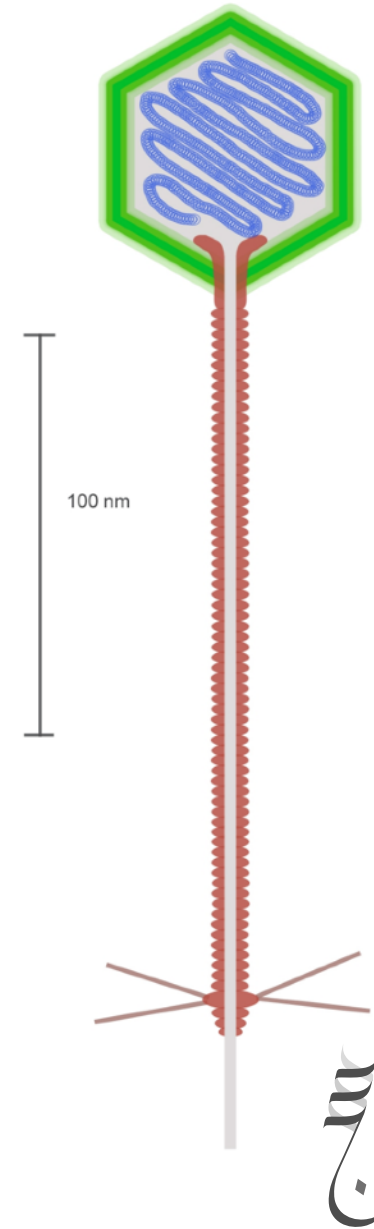
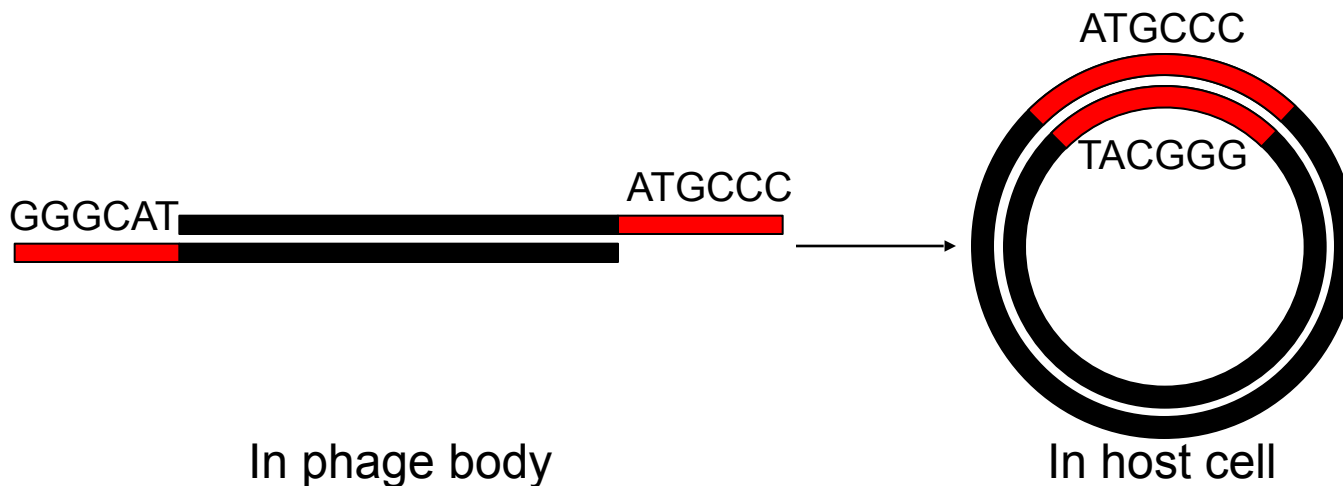

Lambda phage (λ) life cycle

Lambda phage (λ) life cycle can take two forms

Lytic cycle

Lysogenic cycle

- Phage genome is replicated into many copies.
- Progeny assembles in phage particle and gets released.
- The host cell is destroyed (Lysed).

- Phage genome **IS NOT** replicated.
- Phage genome is integrated in the host genome.
- No progeny is produced.
- The host cell is not destroyed.
- Replication of phage genome achieved when the bacterial cell replicates.

Lambda phage (λ) life cycle

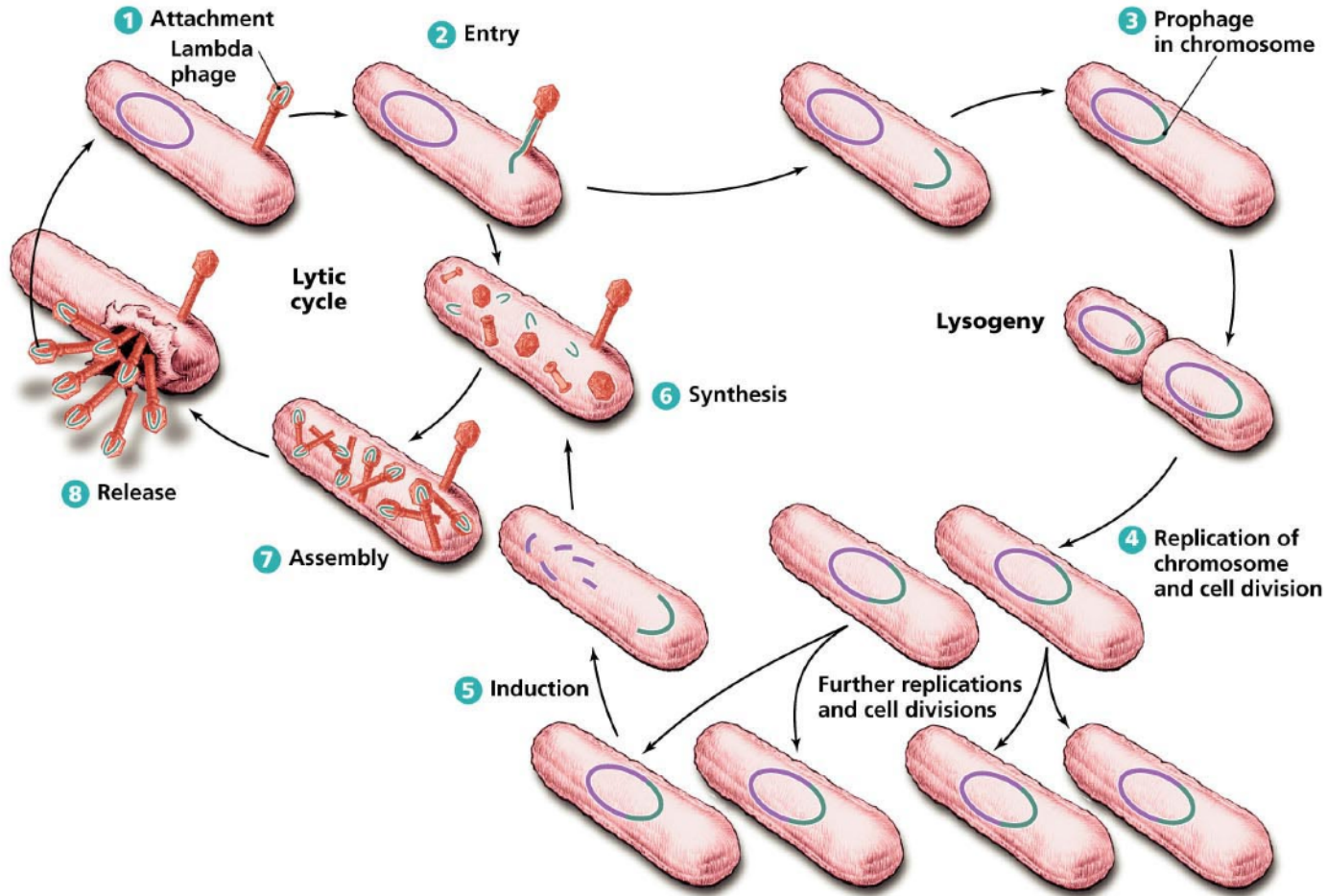

Lambda phage (λ) life cycle



When to use each of the cycles?

What regulates the choice?

A molecular switch!

Lambda phage (λ) genome

A look at phage genome

- Remember sticky ends (COS sequence).

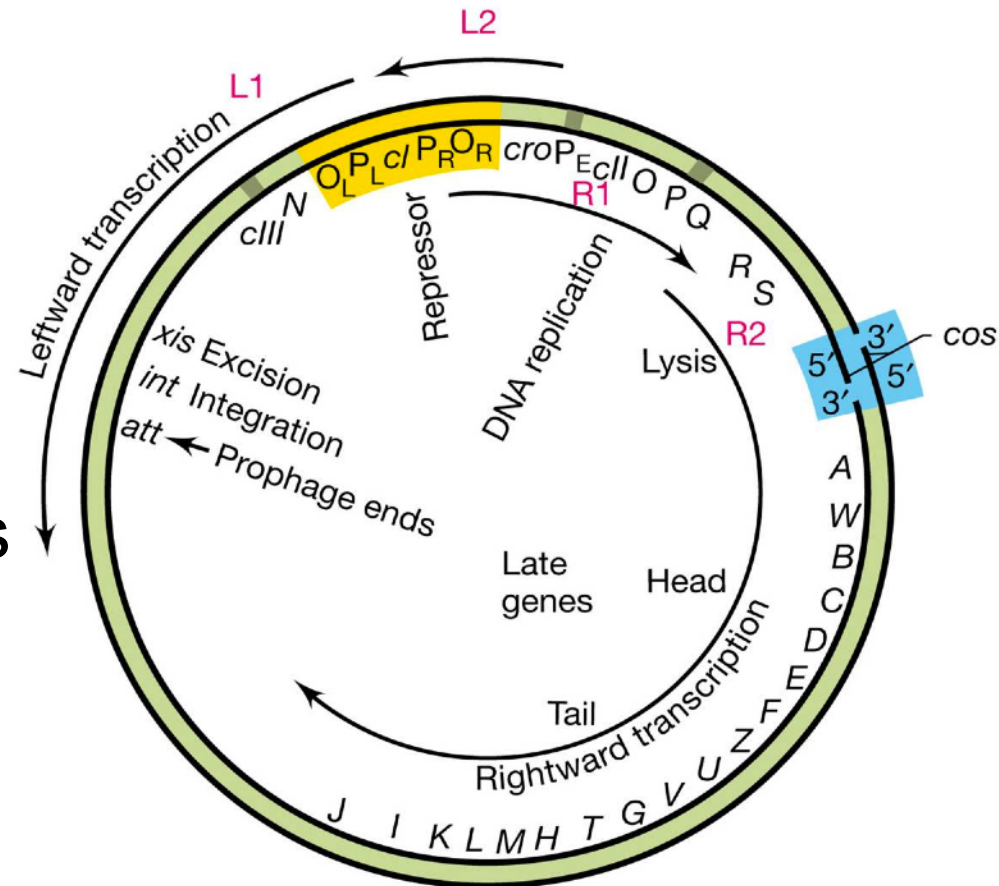

Lambda phage (λ) genome

A look at phage genome

- Transcription can take place in the left direction or right direction (relative to yellow region - repressor).

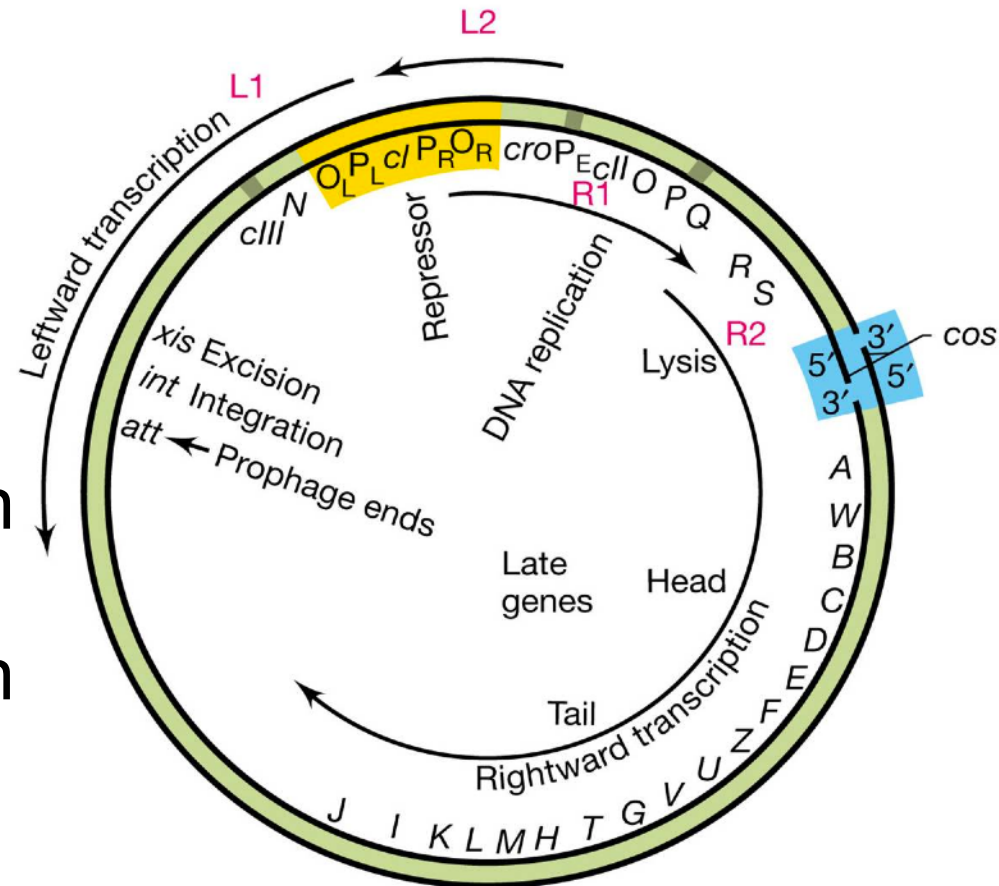

Lambda phage (λ) genome

A look at phage genome

- Transcription rightward turns the genes to replicate the phage genome + lysing the bacterial cell + making the phage body.

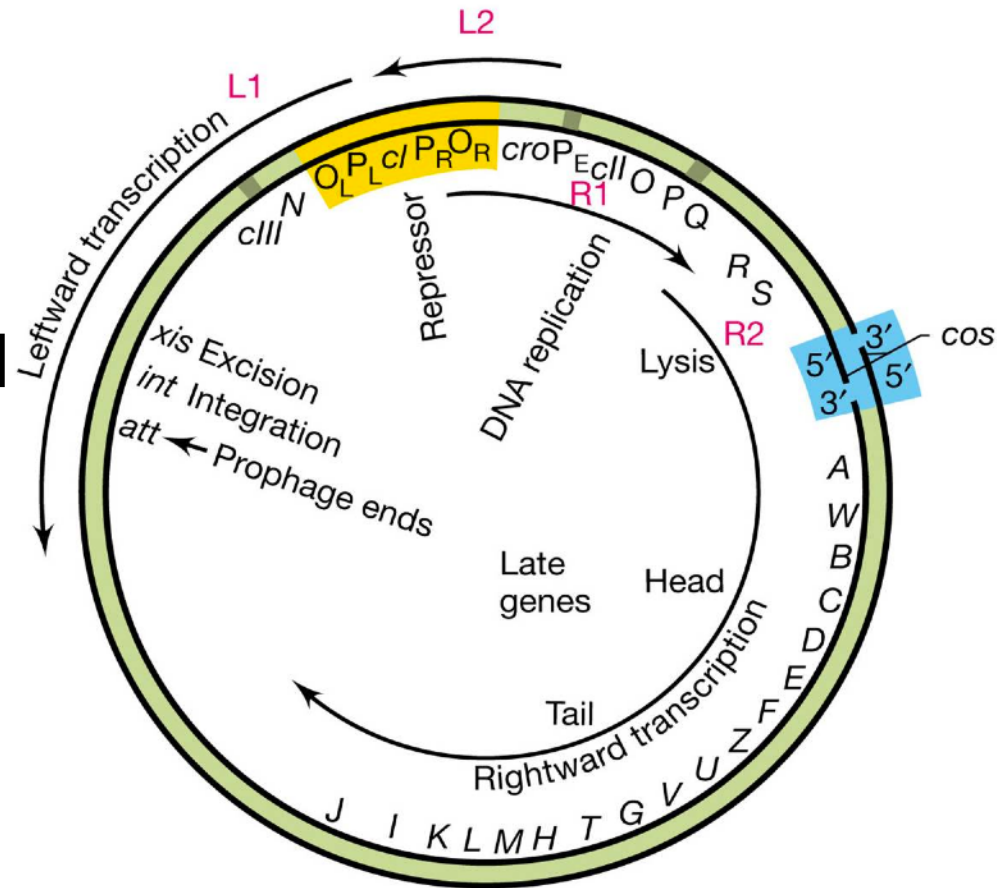

Lambda phage (λ) genome

- Transcription leftward turns the genes to integrate the phage genome into the host cell.

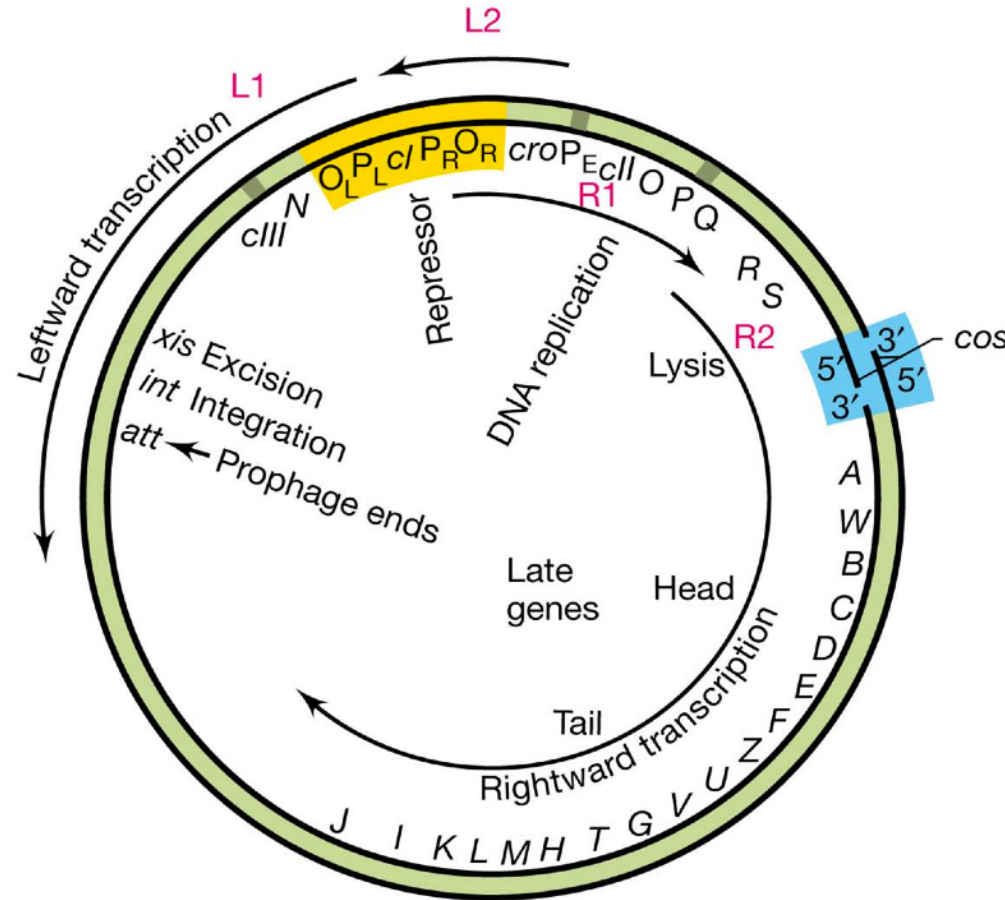

Lambda phage (λ) genome

Let's look into the details of the lambda repressor region (yellow)

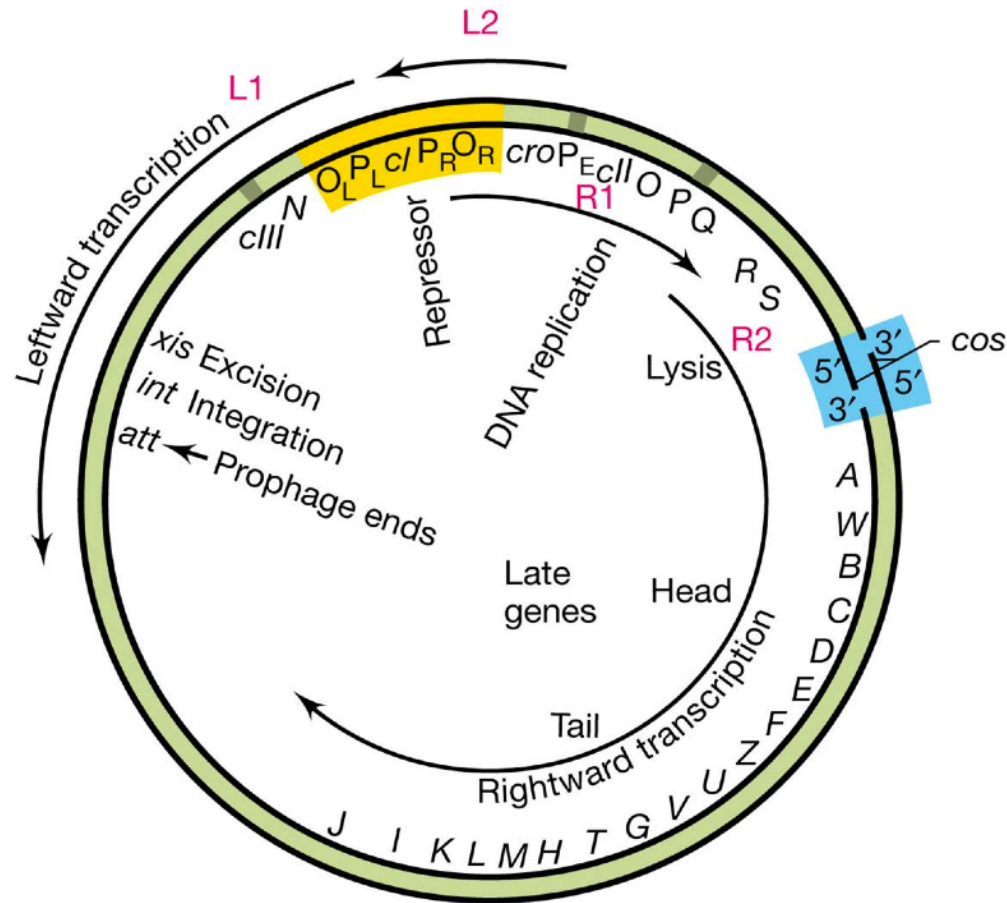

Lambda phage (λ) genome

- Two genes serve as the molecular switch.
- **Lambda repressor protein (CI):** activates the lysogenic pathway.
- **Cro protein:** activates the lytic pathway.

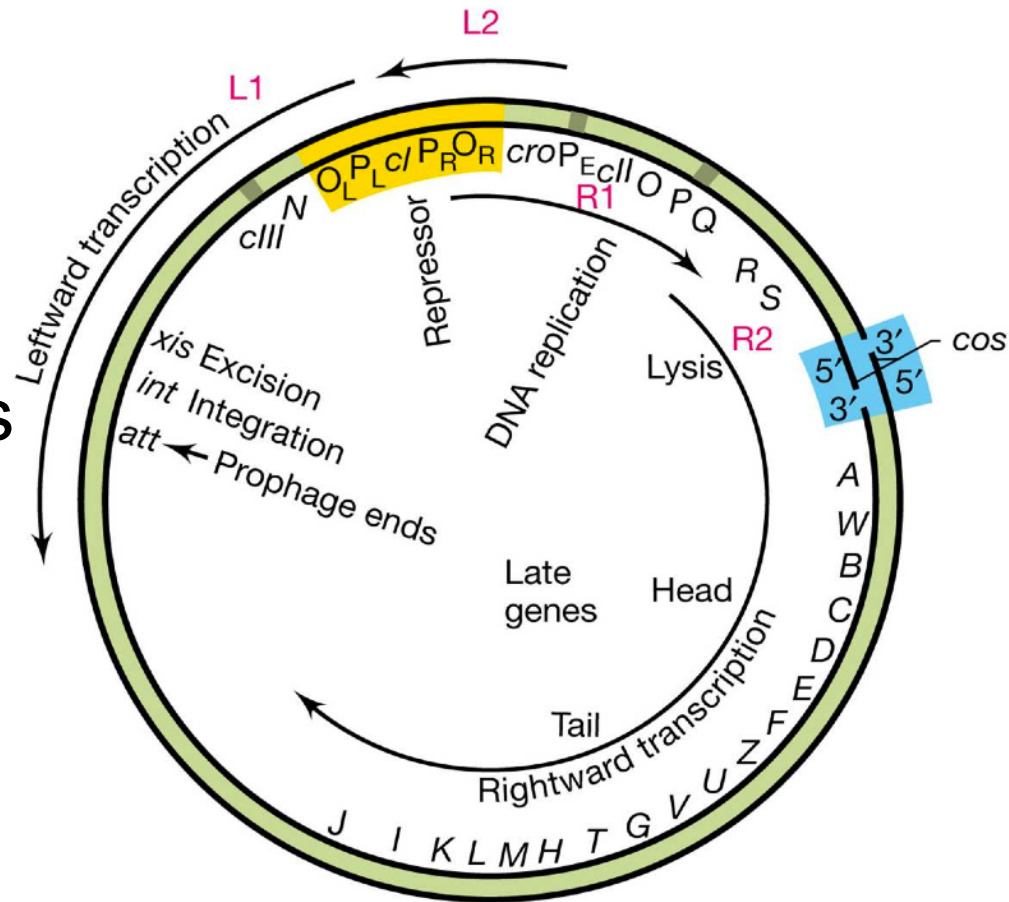

This system is called the **lambda repressor switch**

Lambda phage (λ) repressor

λ repressor-
operator
binding

Helix-Turn-Helix
Motif

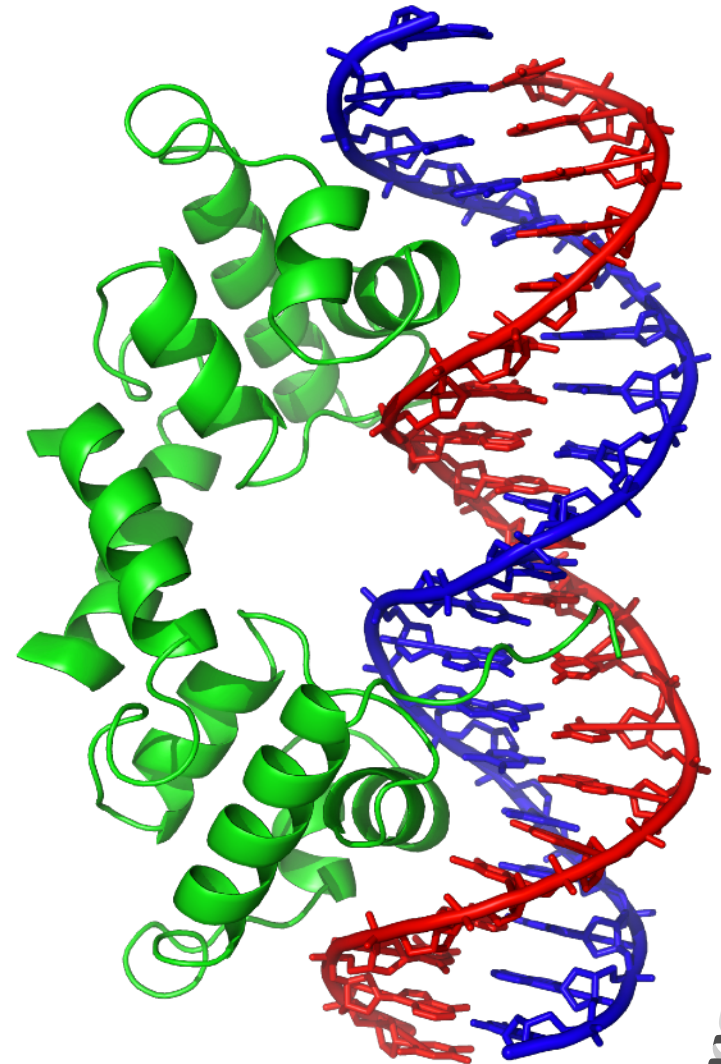
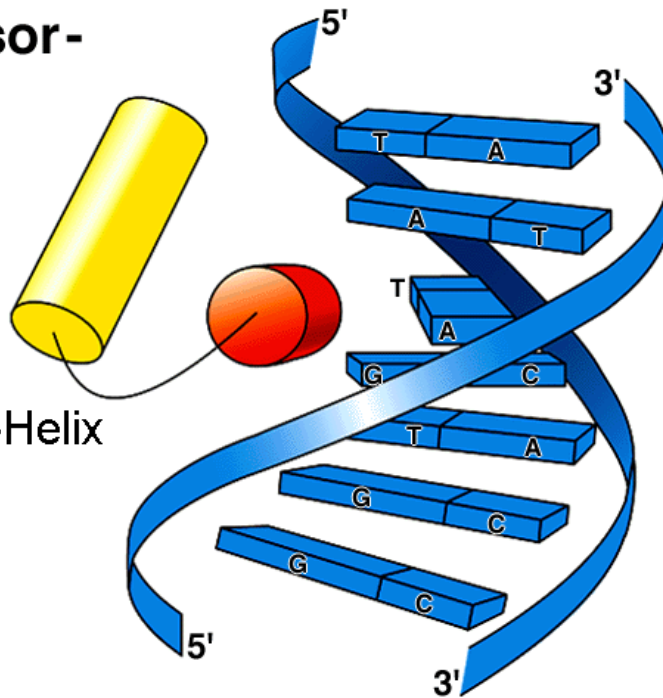

Lambda phage (λ) repressor

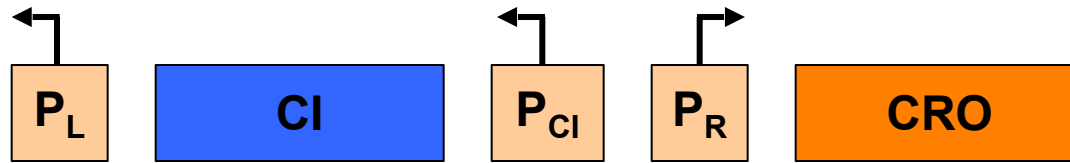

Three promoters are essential for the transcription of λ phage genome:

- P_R : a promoter for transcribing the rightward genes.
- P_L : a promoter to transcribe the leftward genes.
- P_{CI} : a promoter to transcribe CI (lambda repressor gene).

Lambda phage (λ) repressor

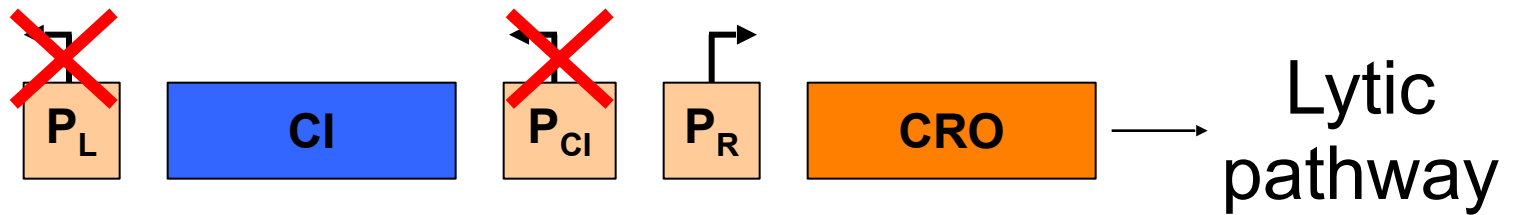

Lytic pathway is achieved when the both P_R and P_L are turned ON and P_{CI} is turned OFF.

What is turning these promoters ON and OFF?

Lambda phage (λ) repressor

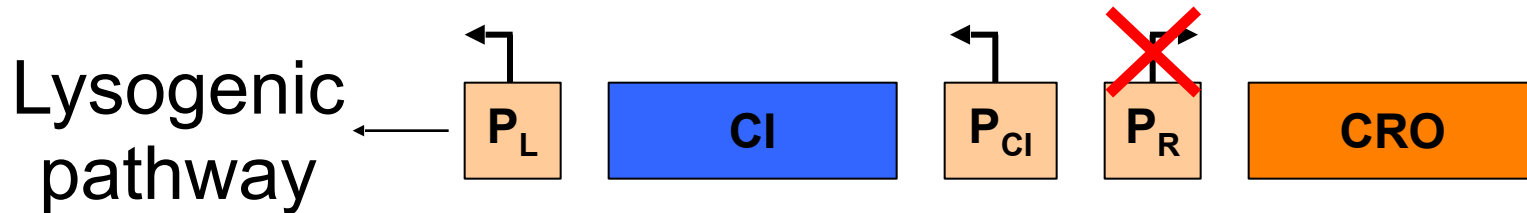

Lysogenic pathway is achieved when the both P_{CI} is turned ON and P_L and P_R turned OFF.

What is turning these promoters ON and OFF?

Lambda phage (λ) repressor

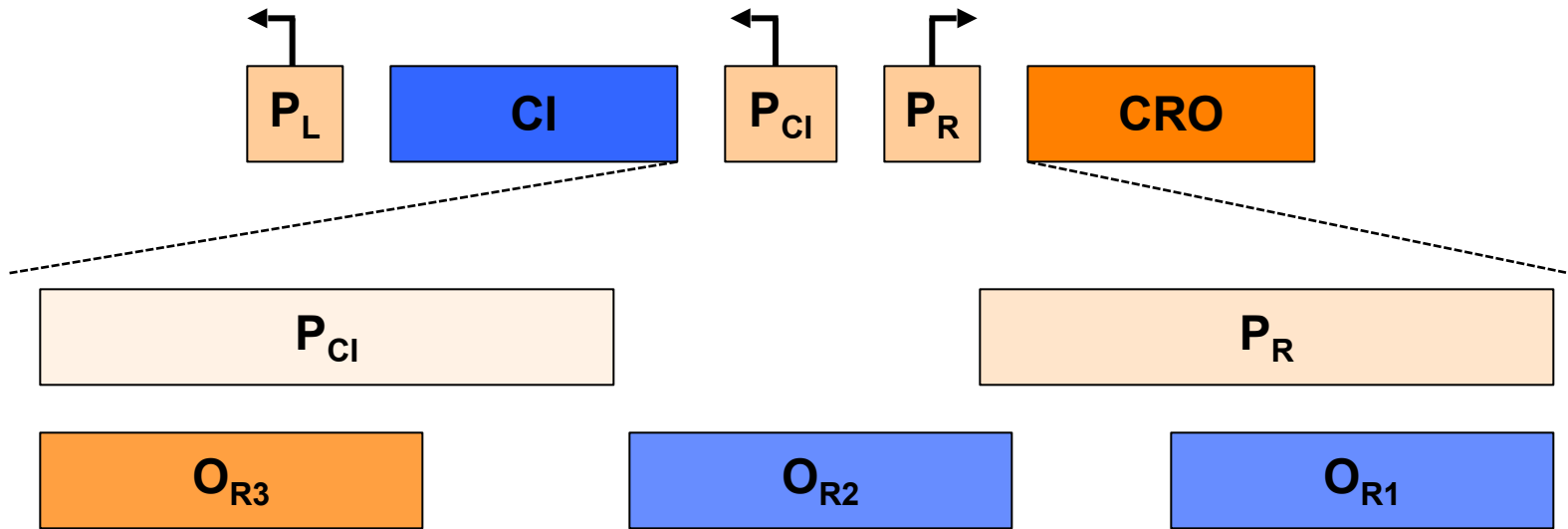

- In the region between CI and CRO genes (that includes P_{CI} and P_R) there are the **DNA motifs** called **operator regions**.

Lambda phage (λ) repressor

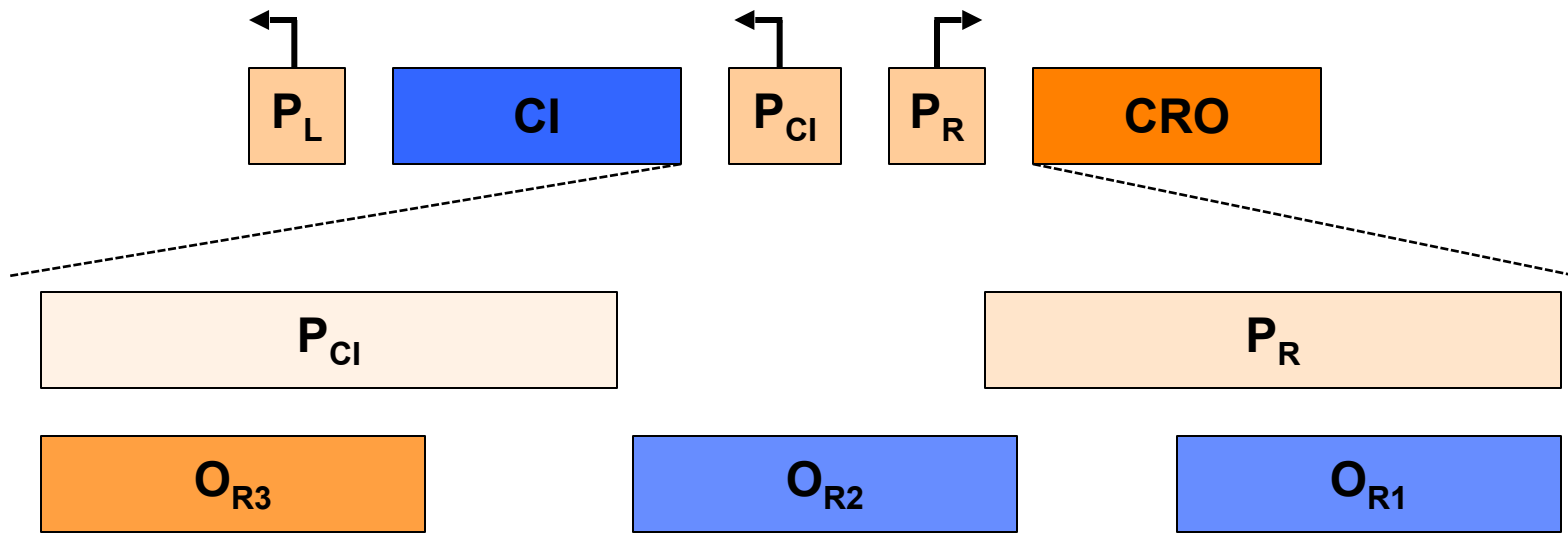

- The operator regions overlap with the promoter regions to look like:



Lambda phage (λ) repressor

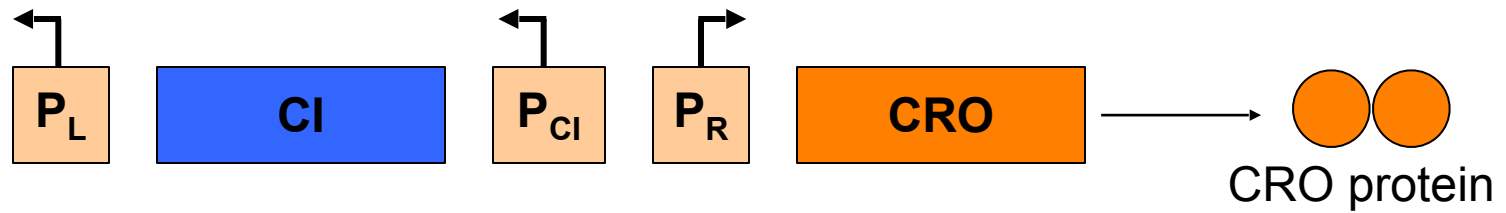

When CRO is expressed a CRO protein is produced

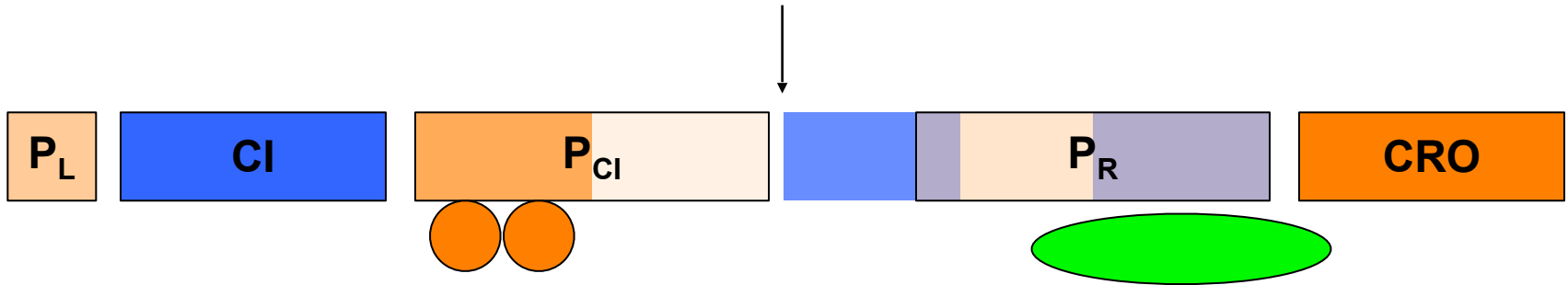

- CRO protein binds to the operator region overlapping with the CI promoter (P_{CI}).
- CRO protein prevents the RNA polymerase from binding to the promoter (P_{CI}) and thus no CI protein is produced.

Lambda phage (λ) repressor

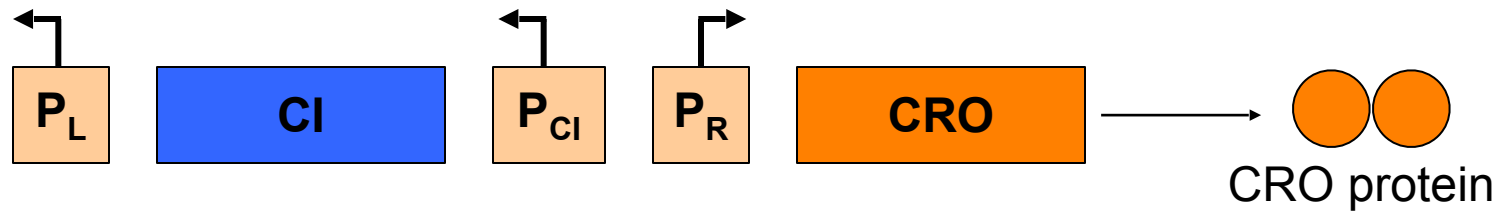

When CRO is expressed a CRO protein is produced

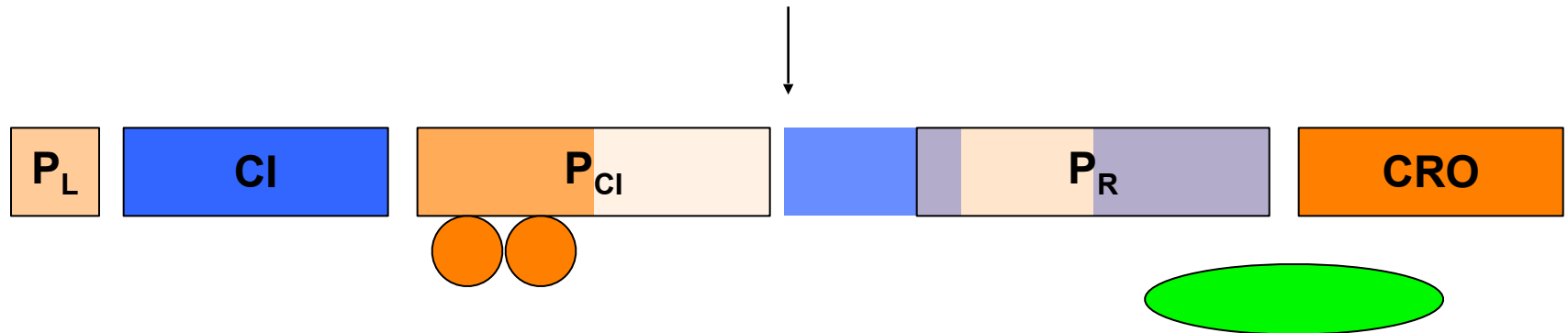

As a result the **lytic pathway** genes get expressed because of the activity of promoters (P_L and P_R).

Lambda phage (λ) repressor

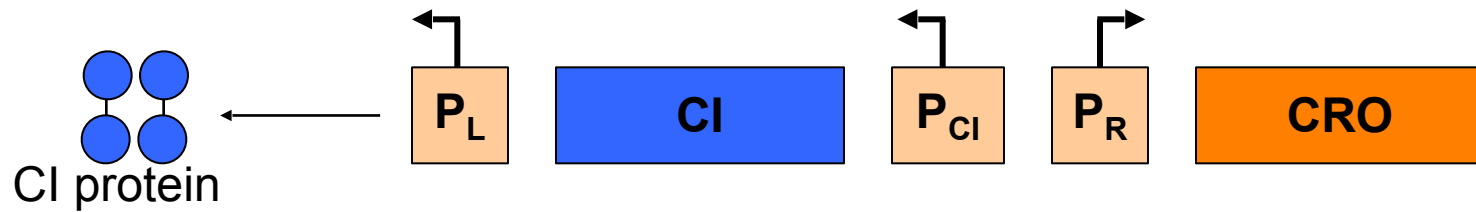

When CI is expressed a CI protein is produced

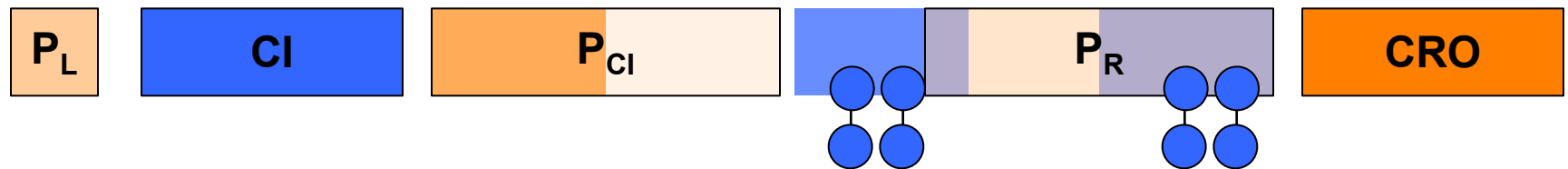

- CI protein binds to the operators overlapping with CRO and other genes promoter (P_R).
- CI protein (helix-turn-helix) prevents the RNA polymerase from binding to (P_R) promoter and thus no CRO or lytic pathway genes produced.

Lambda phage (λ) repressor

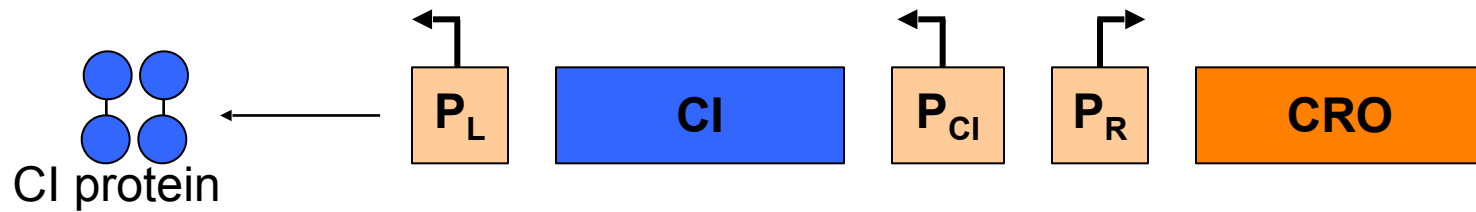

When CI is expressed a CI protein is produced

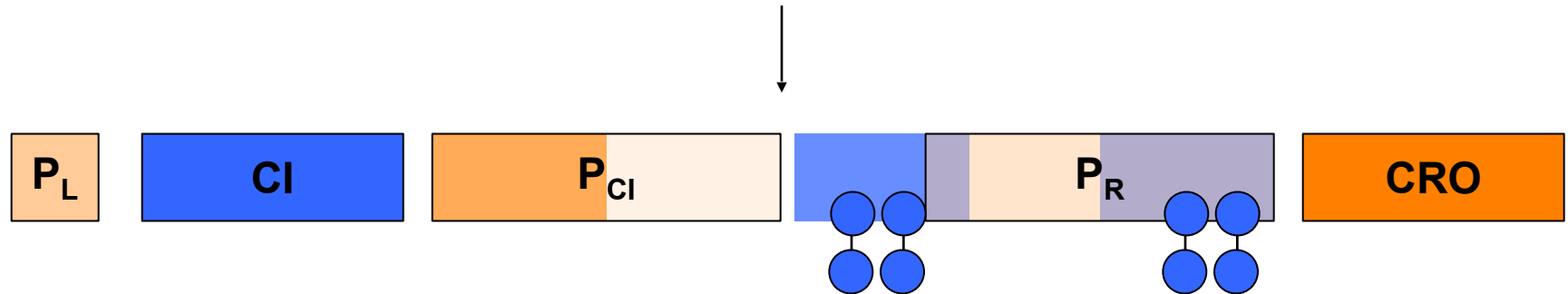

As a result the **lysogenic pathway** genes are expressed

Lambda phage (λ) repressor

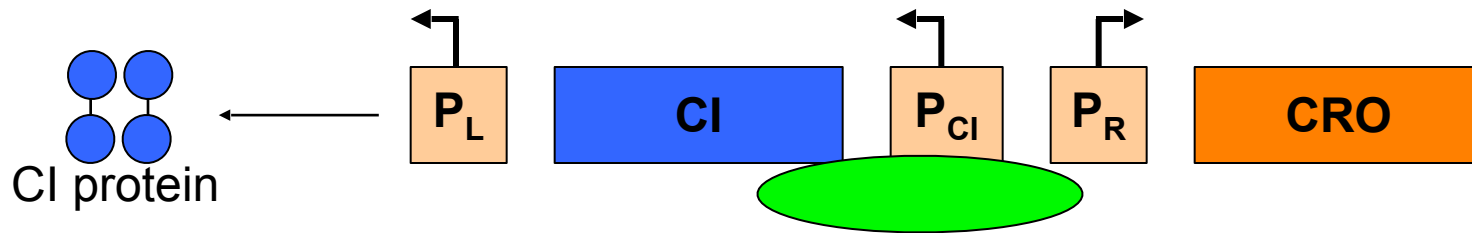

When CI is expressed a CI protein is produced

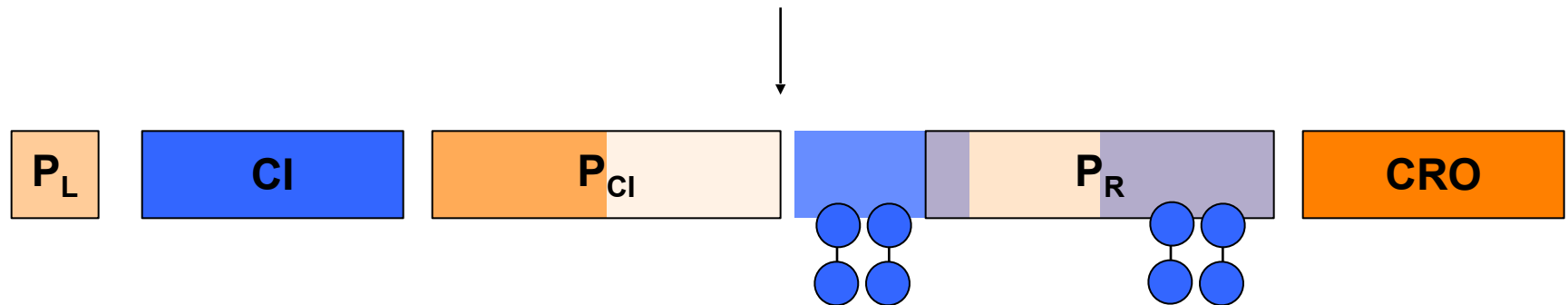

- CI protein binds to the two operator regions ($R1$ and $R2$) cooperatively (one molecule help another bind).

Lambda phage (λ) repressor

- **Cooperative binding depends on:**
 - Affinity (the interaction)
 - Concentration.

Lambda phage (λ) repressor

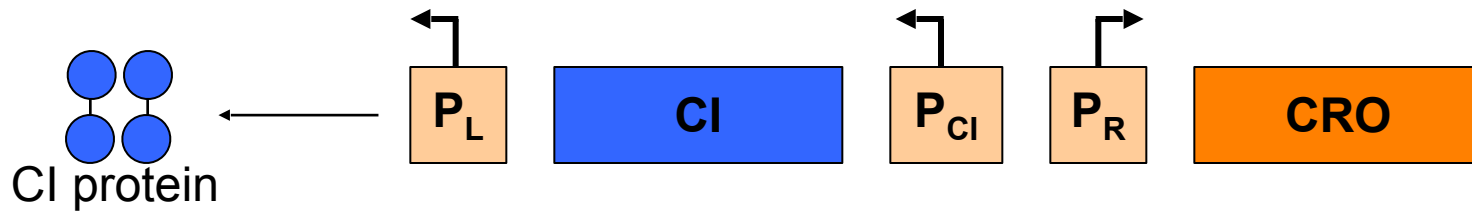

When CI is expressed a CI protein is produced

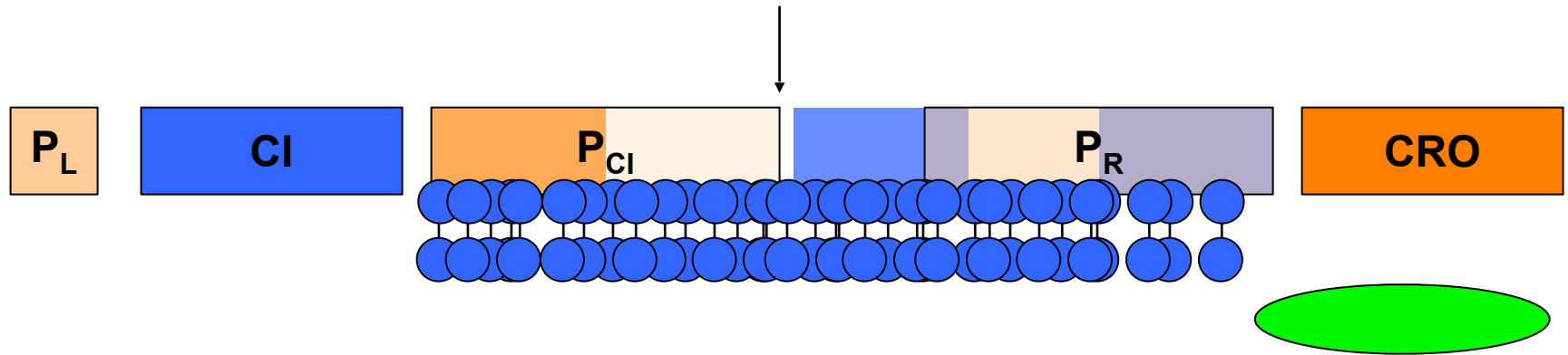

**All promoters are blocked
No further CI protein is produced**

- Cooperative binding of CI protein can also regulate its own expression by slowly occupying the P_{CI} region.

Lambda phage (λ) repressor



Summary

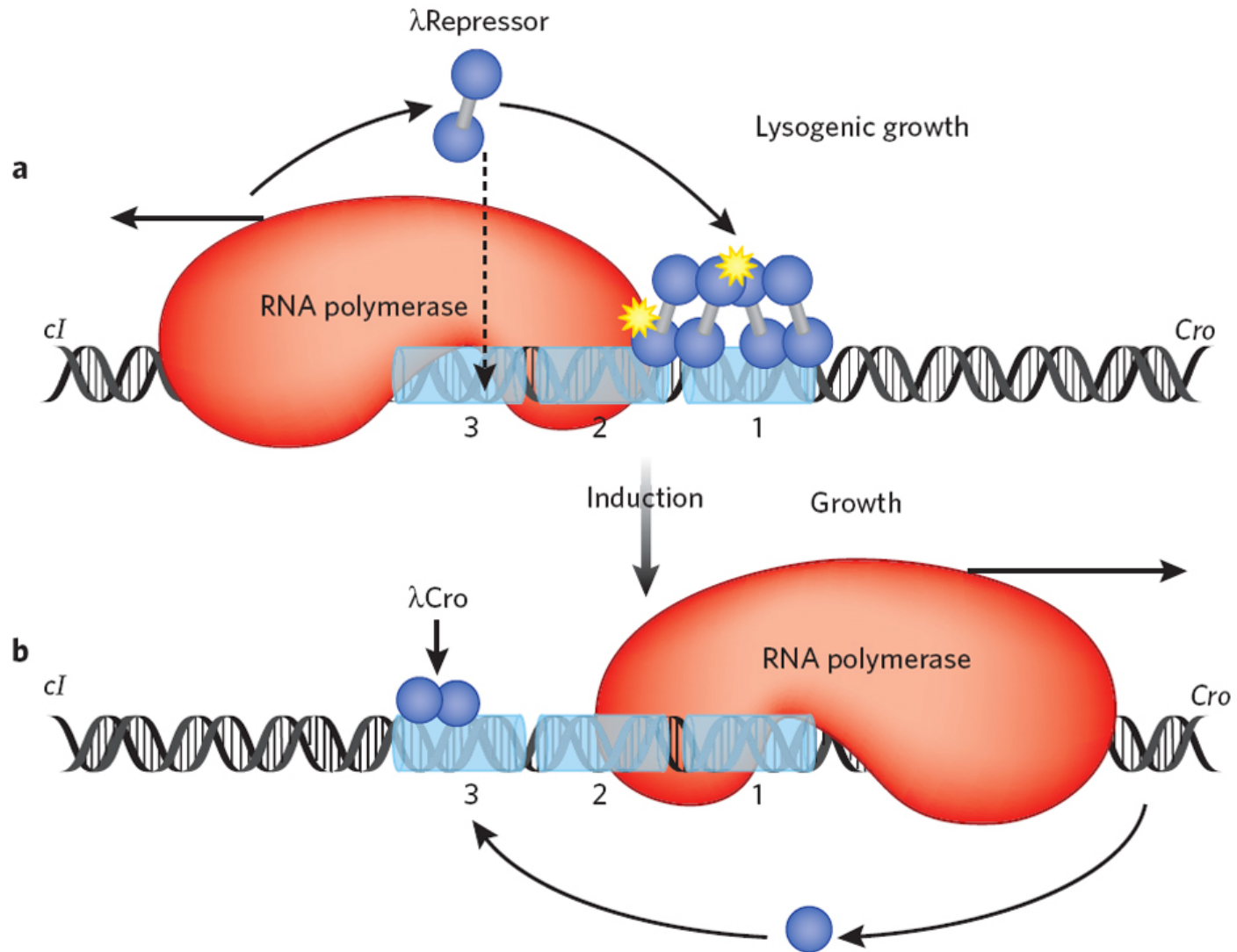

Scenario

- When a bacterial cell is attacked by phage a **SOS (HELP)** state is established. An enzyme is produced called RecA.
- This bacterial enzyme destroy some bacterial enzymes but also destroys the CI protein and prevent cooperative binding.
- When CI is not present, P_R is quickly activated to produce CRO protein which stops the transcription of CI protein.
- The cell goes to a lytic pathway.

Scenario

What would the phage do in bad bacterial growth conditions?

- Bad conditions – no more bacteria around to infect.
- Better to stay in lysogenic state until conditions become better.

Scenario

When few phages infect a bacterial cell?

- A lytic pathway is likely to take place because:
 - Not enough repressor is produced.
 - It is in the best interest of one phage to make more of itself.

Scenario

When many phages infect a bacterial cell?

- A lysogenic pathway way is likely to take place because:
 - A lot of repressor is produced.
 - Too much competition for resources.

Question

In which life cycle pathway the phage replicates its genome?

How does the phage replicates its genome?

To know

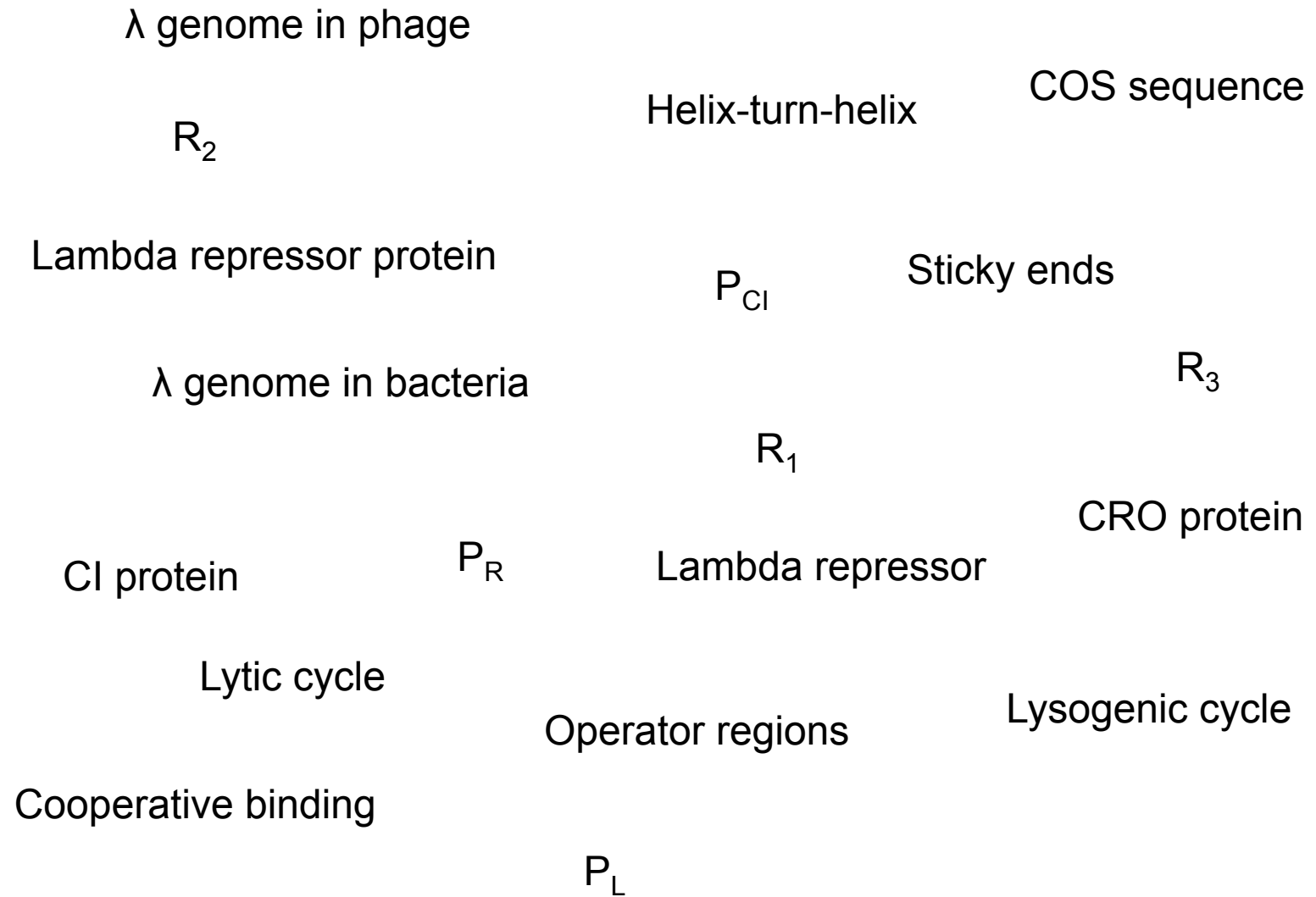

Expectations

- You know phage's life cycles.
- You know the general structure of lambda phage genome.
- You know the molecular switch to lytic cycle.
- You know the molecular switch to lysogenic cycle.
- you generally know the conditions for choosing one cycle versus another.

For a smile

